

CLAMPING PARTS ACCESSORY 4 PAIR

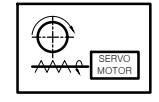
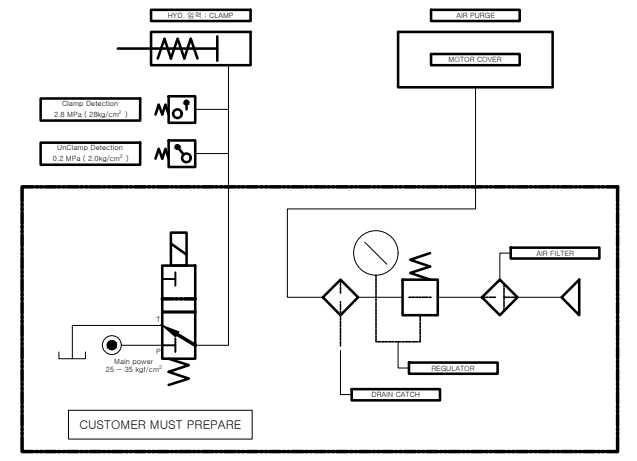
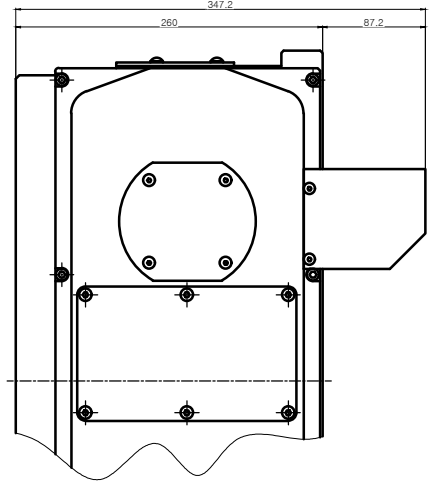
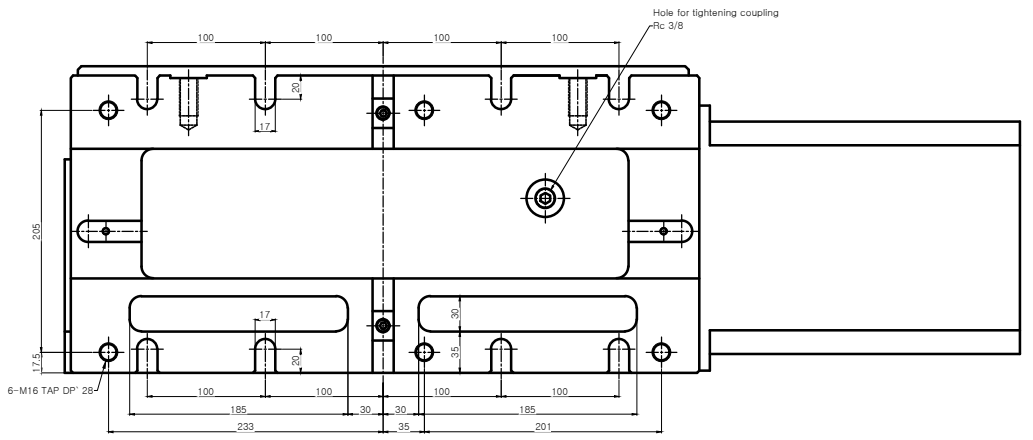
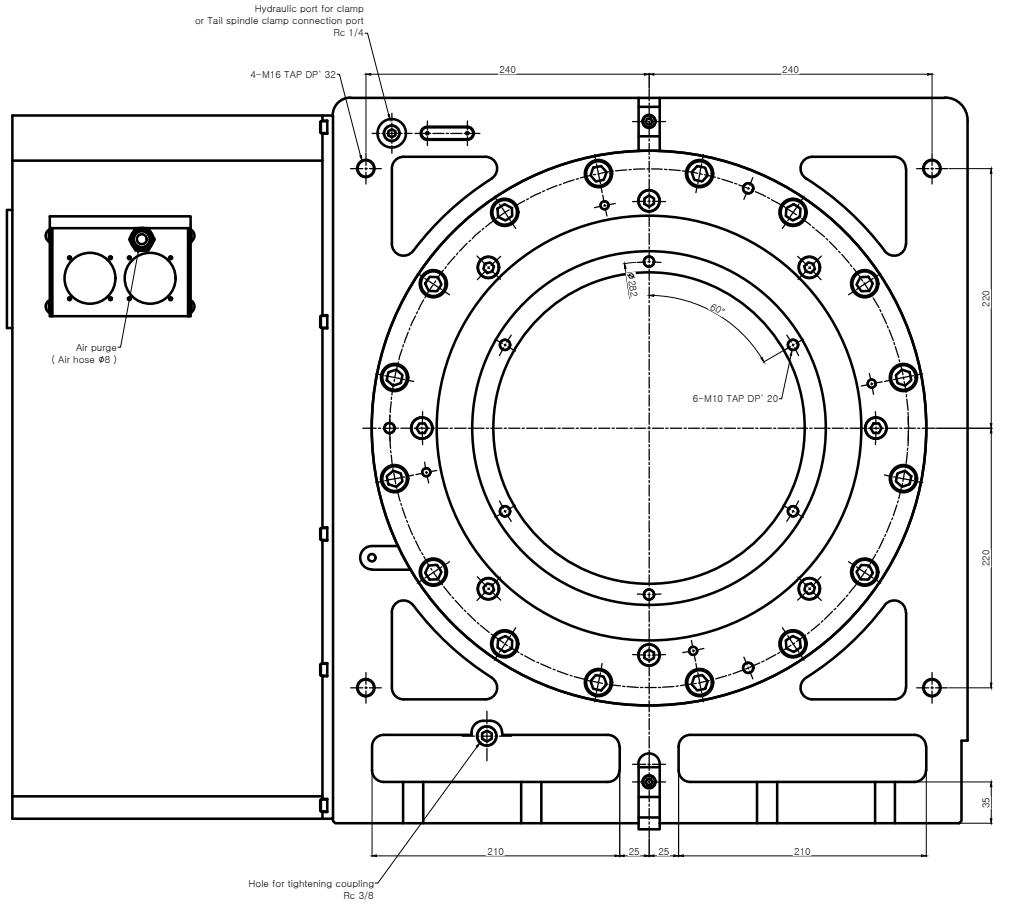
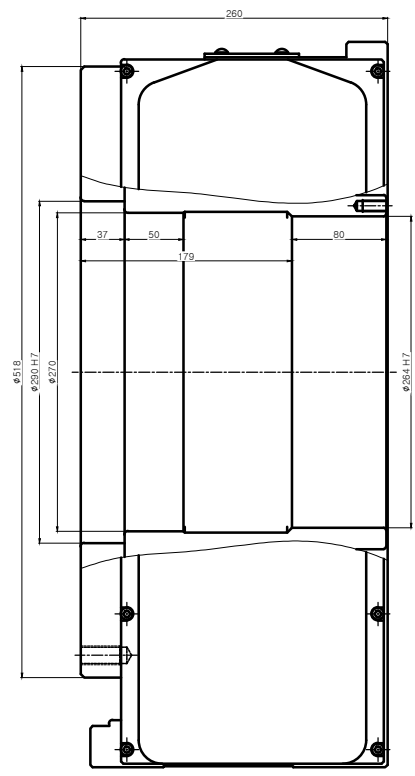
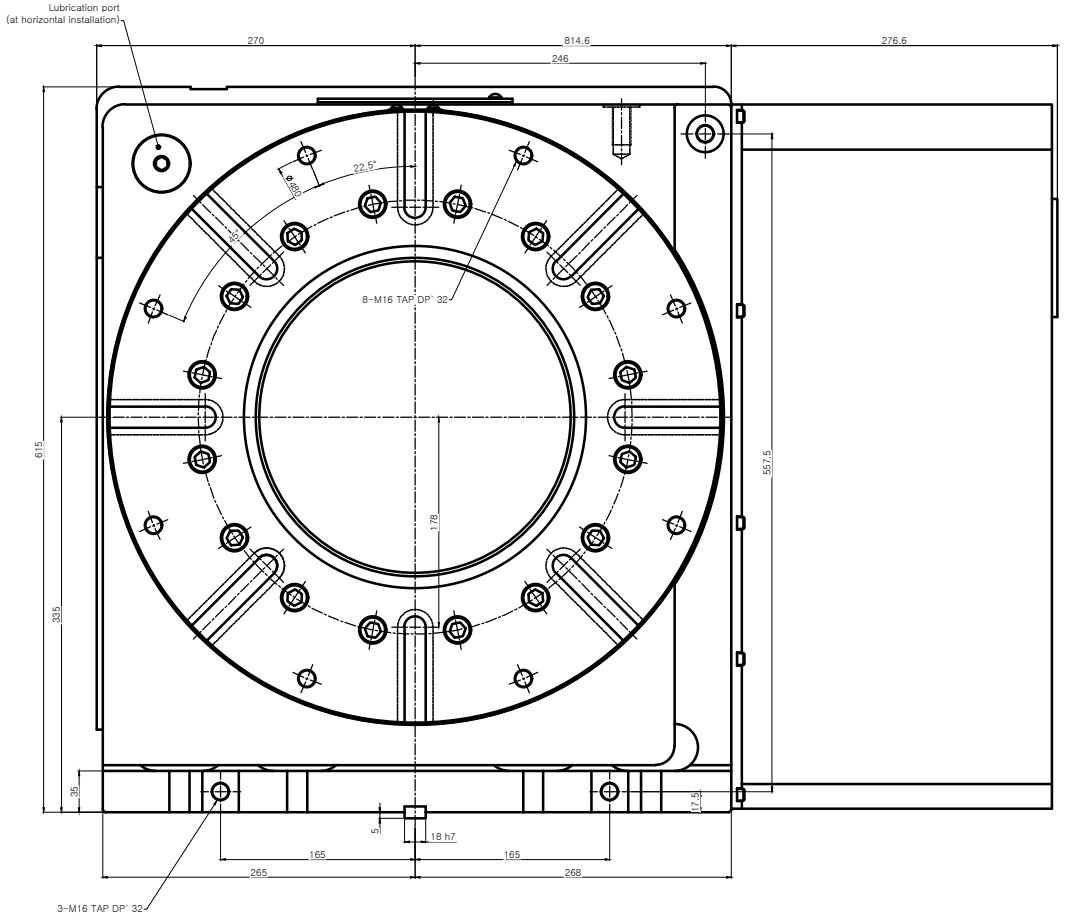
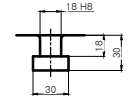

SPECIFICATION	
테이블 직경 Table Diameter	φ518 mm
센터 높이 Center Height	335 mm
테이블 내경 Table Inner Diameter	φ290 H7
관통경 Spindle Through Hole Diameter	φ264 H7
클램프 방식 Clamp Method	Hydraulic 25 ~ 35 kg/cm ²
관성 모멘트 Allowable Work Inertia	19.97 kg·m ²
클램프 토크 Clamp Torque	3200 N·m
회전 속도 Max. Spindle Speed	16.6 min ⁻¹ (NOT FOR MAX 2000 mm ³)
기어비 Gear Ratio	1 / 120
무게 Weight	430 kg
기어 오일 Gear Lubrication	ISO VG #220
허용하중 ALLOWABLE MASS OF WORK	600 kg [HOR.] 300 kg [VER.]